

**PRODUCT CROSS REFERENCE:
Large Frame Contactors
CA6/CA5 to CA9**

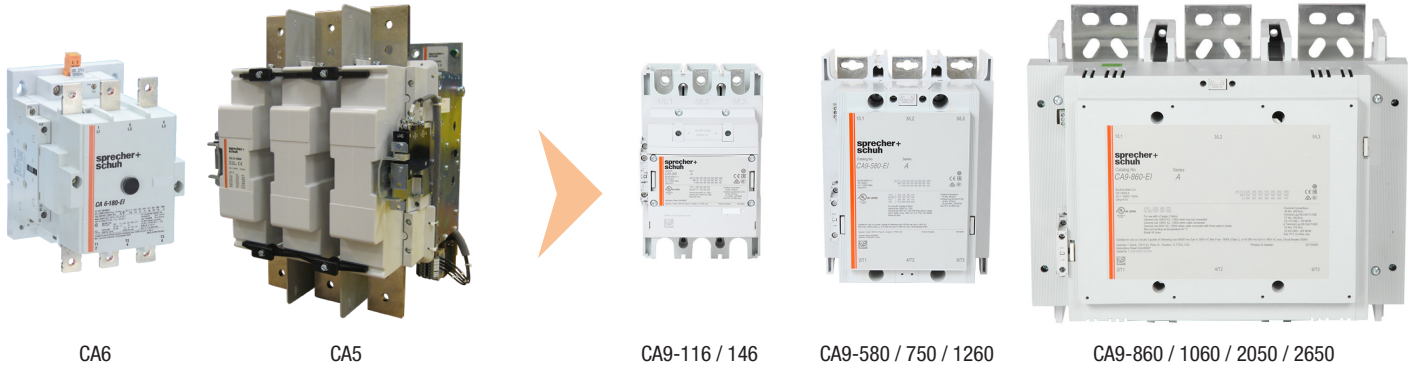

Obsolete CA6 & CA5

CA9 (116-2650 Amps)

Why Upgrade or Migrate

While Sprecher+Schuh series CA6 and CA5 large frame IEC contactors have provided dependable service to many customers, they will no longer be available for sale after January 31, 2019.*

The replacement CA9 series contactors provide a reduced width footprint, reduced weight, lower coil power consumption and simplified selection.

CA9 series Contactors Features and Benefits

Electronic wide-range AC/DC coils

- Low inrush and hold-in power consumption
- Optional integrated PLC interface
- Integrated surge suppression
- Easier selection

Smaller, lighter

- Reduced panel footprint makes retrofiting easier and can enable smaller enclosures

Safety Solutions

- Mirror contact performance
- SUVA third party certified

Approvals

- CE Marked
- cULus Listed (File No. E41850/ E196120, Guide NLDX, NLDX7)
- CCC
- EAC
- RCM

Identify, Mitigate and Help Eliminate the Risk of Automation Obsolescence

In today's economy, it is necessary to have migration solutions that help you to achieve increased productivity and lessen your risk of maintaining your legacy equipment. You need to work with a supplier that has the product, service and industry knowledge to partner with you on an upgrade strategy that will help you maximize your competitive advantage.

Sprecher+Schuh will work with you to outline a plan that fits your application needs and long-term goals. We can help you migrate all at once or in phases, at the pace that is comfortable for you and fits your budget.

With your goals in mind, Sprecher+Schuh has developed a migration strategy that will allow you to quickly and easily migrate from CA6 and CA5 contactors to CA9 contactors.

* Discontinued date may be subject to change.

CA9 Catalog Scheme

This catalog number chart provides a general guide to creating a CA9 catalog number to match your application. Not all possible combinations are valid.

Catalog Number:



Configuration	
CA9	Contactors
CAU9	Reversing Contactors

Contactor Size	
CA9	AC-3, 400 / 415 V
116(EI)	116 A
146(EI)	146 A
190(EI)	190 A
205(EI)	205 A
265(EI)	265 A
305(EI)	305 A
370(EI)	370 A
400-EI	400 A
460-EI	460 A
580-EI	580 A
750-EI	750 A
860-EI	860 A
1060-EI	1060 A
1260-EI	1260 A *
2050-EI	2050 A *
2650-EI	2650 A *

* AC-1 only

Auxiliary Contactor	
11	(1)N.O. & (1)N.C. Auxillary
22	(2)N.O. & (2)N.C. Auxillary

Coil Code	
Control Voltage / Sizes	
24W	24-60V AC/DC / 116(EI)...370(EI)
48W	48-130V AC/DC / 116(EI)...370(EI)
120W	100-250V AC/DC / 116(EI)...370(EI)
480W	250-500V AC/DC / 116(EI)...370(EI)
24W	24-60V DC (w/ PLC input) / 400-EI...750-EI, 1260-EI
48W	48-130V AC/DC (w/ PLC input) / 400-EI...750-EI, 1260-EI
120W	100-250V AC/DC (w/ PLC input) / 116(EI)...2650-EI
480W	250-500V AC/DC (w/ PLC input) / 116(EI)...750-EI, 1260-EI

Options	
blank	116(EI)...2650EI
L	116(EI)...146(EI)

Catalog No. Example: CA9 - 116 - 11 - 24 - L

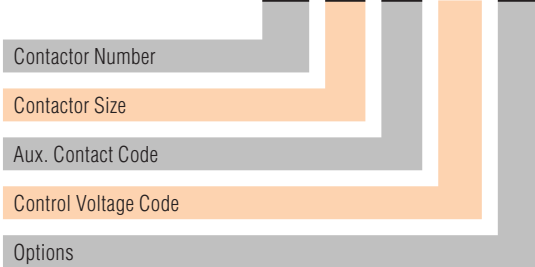

Conversion Assistance

In the catalog section of CA9 contactors, Sprecher+Schuh includes an *Obsolete Contactor Cross-Reference* page that provides the rating of the old obsolete contactor and current CA9 series contactor.

Contactors Cross Reference, Series CA1 & CA6 to Series CA9 (Open Type Only)

I _e [A]		Ratings for Switching AC Motors (AC2 / AC3 / AC4)										Series CA1 Obsolete	Series CA6 Obsolete	Series CA9 Equivalent
		kW (50 Hz)				UL/CSA HP (60 Hz)								
		AC-3	AC-1	230V	400V / 415V	500V	690V	1 Ø		3 Ø				
115V	230V							200V	230V	460V	575V			
115	250	37	64/66	80	111	10	25	40	40	75	100		CA6-115	
116	160	30	55	75	55			30	40	75	100			CA9-116
						10	25	40	40	75	100	CA1-60		
140	250	45	78/82	80	111	15	30	40	50	100	125		CA6-140	
146	225	45	75	90	90			40	50	100	125			CA9-146
						15	30	50	50	100	125	CA1-100		
180	250	57	101/105	98	135	~	40	50	60	150	150		CA6-180	
190	275	55	90	90	132			50	60	125	150			CA9-190
						~	~	60	60	150	150	CA1-150		
205	350	55	110	110	160			60	75	150	200			CA9-205
210	350	67	118/122	147	205	~	50	60	75	150	200		CA6-210	
						~	~	75	100	200	250	CA1-250		
250	350	80	140/145	177	250	~	~	75	100	200	250		CA6-250	
265	400	75	132	160	200			75	100	200	250			CA9-265
300	450	97	170/176	213	293	~	~	100	125	250	300		CA6-300	
305	500	90	160	200	250			100	125	250	300			CA9-305
						~	~	150	150	350	400	CA1-480		
400	600	110	200/220	250	315			125	150	350	400			CA9-400
420	500	135	238/250	298	424	~	~	150	175	350	400		CA6-420	
460	700	132	250	315	355			150	200	400	500			CA9-460
580	800	160	315/355	400	500			200	250	500	600			CA9-580
630	800	200	355	450	500	~	~	200	250	500	600		CA6-630	
750	1050	220	400/425	520	600			250	300	600	700			CA9-750
860	1000	250	500	560	~	~	~	250	300	600	700		CA6-860	
860	1350	257	475/500	560	800			~	400	800	1000			CA9-860



CA1-10
Contactor

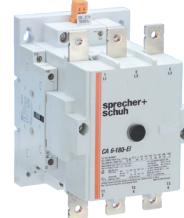

CA6-180-EI contactor



CA9-400-EI contactor

Approximate height and width comparisons: CA9 contactors to equivalent CA6/CA5 contactors

Dimensions are shown in millimeters (inches). Drawing scales vary by size of contactors and are intended to provide approximate visual comparisons only.

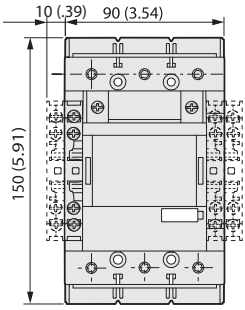

CA9 116 / 146

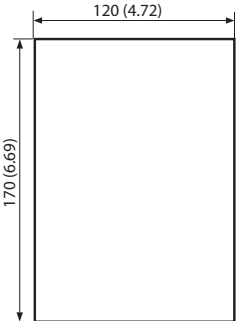

CA6 115 / 140

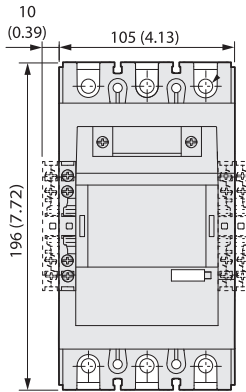

CA9 205

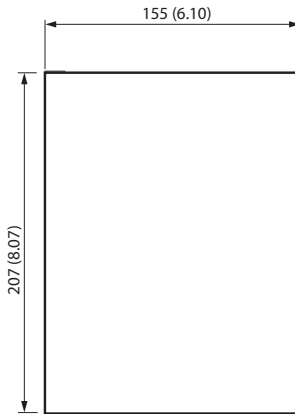

CA6 210

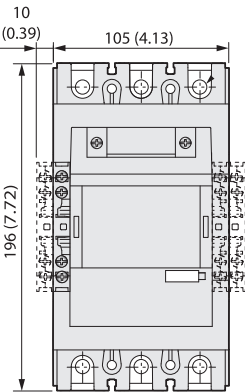

CA9 190

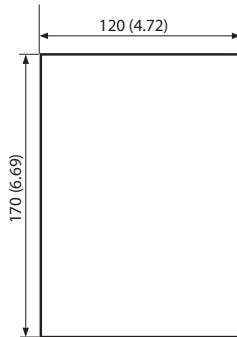

CA6 180

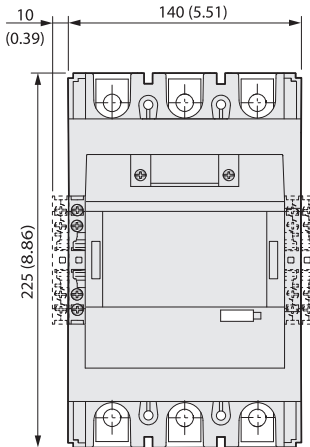

CA9 265 / 305 / 370

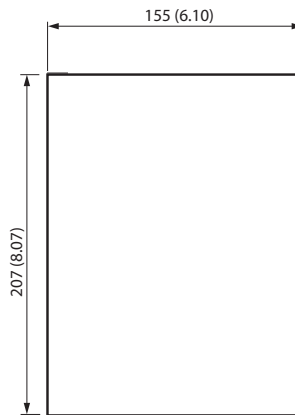

CA6 300

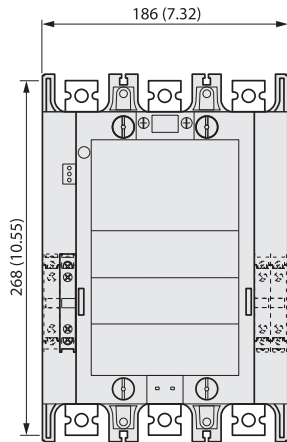

CA9 400 / 460

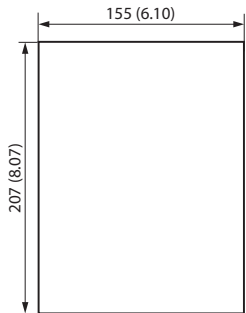

CA6 420

Approximate height and width comparisons: CA9 contactors to equivalent CA6/CA5 contactors

Dimensions are shown in millimeters (inches). Drawing scales vary by size of contactors and are intended to provide approximate visual comparisons only.

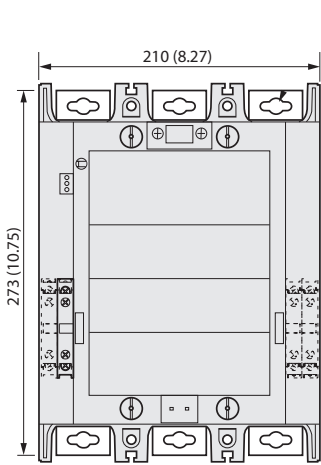

CA9 580 / 750

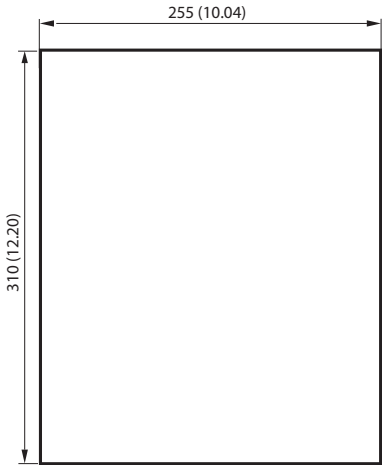

CA6 630 / 860

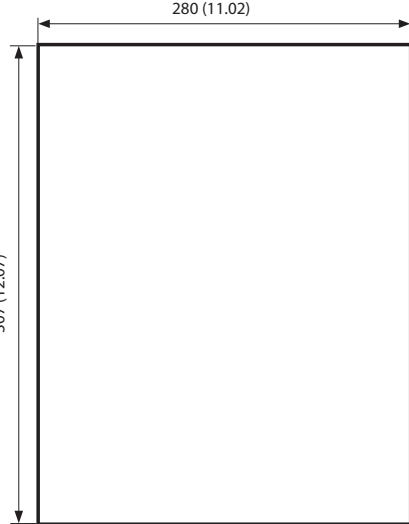

CA5 700

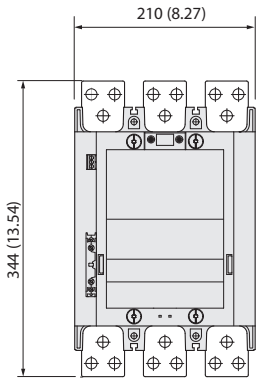

CA9 1260

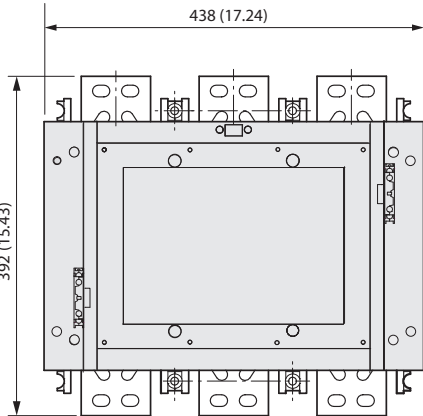

CA9 860 / 1060 / 2050

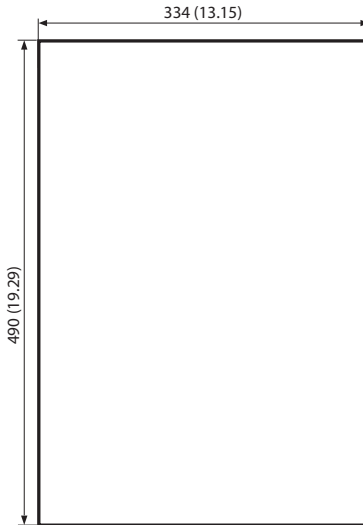

CA5 1000 / 1200



Sprecher + Schuh US Division Headquarters

15910 International Plaza Drive
Houston, TX 77032

Customer Service: (877) 721-5913

Fax: (800) 739-7370

Sprecher + Schuh Canada

Customer Service: (905) 475-6543

Fax: (905) 475-0027

www.sprecherschuh.com



Large Frame Contactors
CA6 to CA9
Cross Reference

PUB ID: CROSS-CA6CA9_v118

08/2018

Sprecher + Schuh has provided reliable control and protection solutions for its customers since 1903.

Today, Sprecher + Schuh offers a wide range of low-voltage industrial control products, including contactors, a variety of relays, starters, push buttons, switches, terminals and controllers, to name a few. All of our products are crafted with precision and tested rigorously for performance — far exceeding industry standards. Moving forward, we continue along the path of constantly seeking innovative ways to provide solutions for our customers. It is by this philosophy that Sprecher + Schuh has come to be the industrial control manufacturer of choice for many customers around the globe seeking quality, reliability, and a name they can trust.